

Operating Instructions

Technical Data

Frequency range	4-stage adjustable: 20 – 140 kHz
Inductance range	20 – 1.500 μ H
Sensitivity	4-stage adjustable
Response time	approx. 120 ms
Power supply	230 V AC \pm 15 %; 12-24 V AC / DC \pm 15 %
Current input	100 mA
Output	2 relays
Max. contact rating	5 A / 230 V AC
Temperature range	-40 °C to +80 °C
Dimensions	75 x 40 x 76 (90 incl. connector) mm (H x W x D)
Weight	approx. 220 g

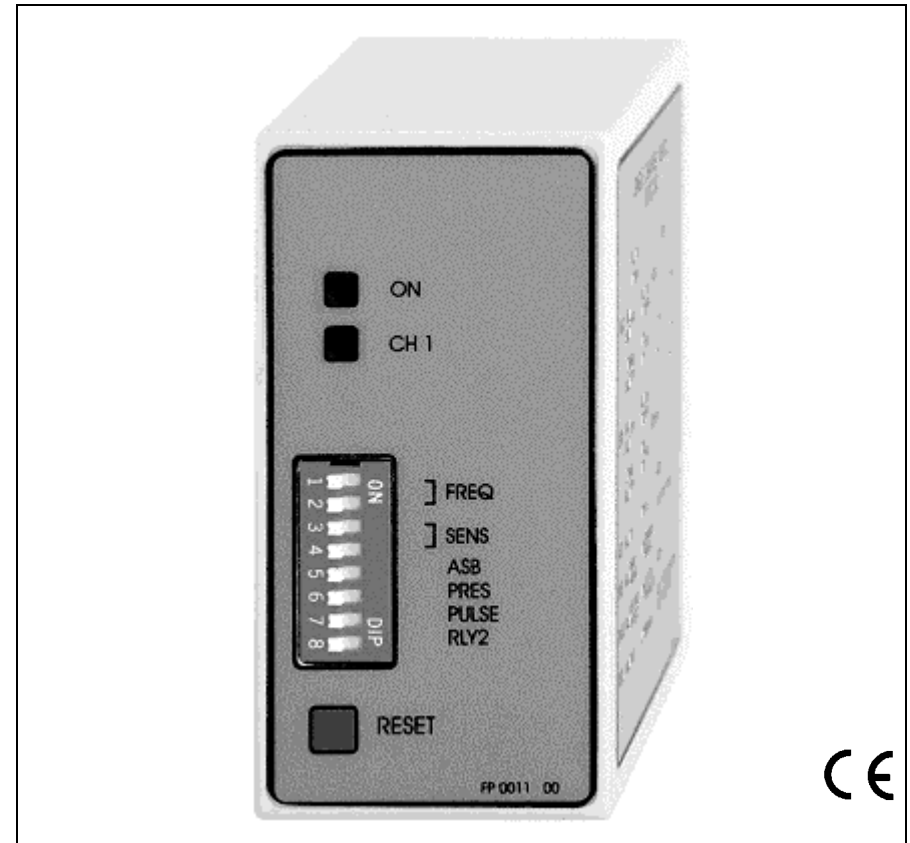

Induction Loop Detector

ILD11
ILD12

230 V AC
12 - 24 V AC/DC

Operating Instructions

ELDAT 

Fig. 1 (unit front)

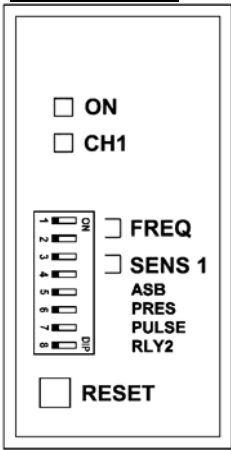
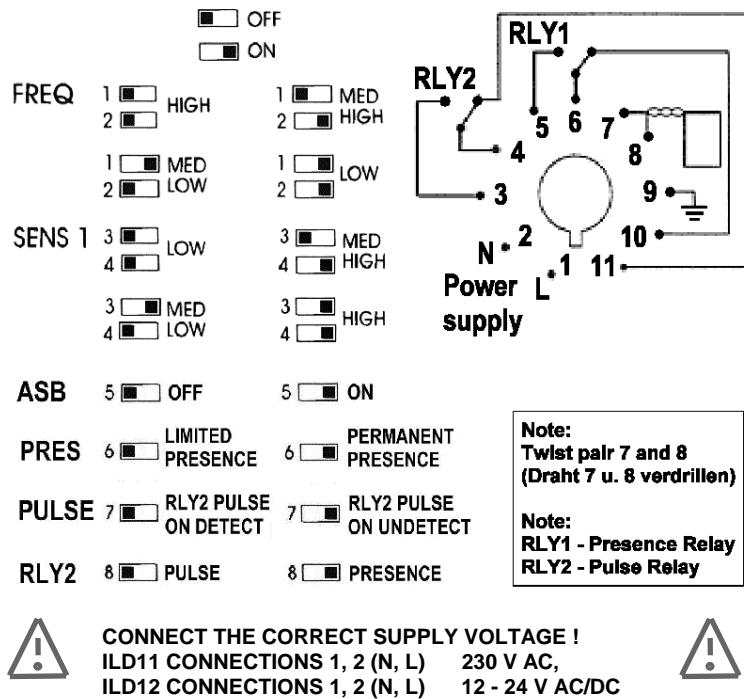

Fig. 2 (Connection scheme, see also side of casing)



PULSE Response Mode Relay 2

The response mode of relay 2 can be set via switch 7:

Switch 7: PULSE



Note:

Adjustments via switch 7 are only possible if relay 2 was previously set for pulse operation, i.e. set RLY2 switch 8 to PULSE!

RLY2 Operating Mode Relay 2

The relay output of relay 2 can be set for either pulse operation (PULSE) or continuous operation (PRESENCE).

Switch 8: RLY2



In the continuous operating mode (PRESENCE), the output remains switched as long as a vehicle is located within the loop's range of action. With pulse operation (PULSE) the output relay switches for approx. 0.8 s once the loop has responded.

FAIL-SAVE, FAIL-SECURE Operating Mode Relay 1

The relay output of relay 1 is permanently set for continuous operation (PRESENCE).

The relay output of relay 1 works in the FAIL-SAVE mode (closer connection 5-10) or in the FAIL-SECURE mode (opener 6-10).

In the event of brief power failures or by pressing the reset button, the output of relay 1 is defined for the switching of 1 pulse. By comparing the outputs of relays 1 and 2, a glitch in the power supply or a reset can therefore be detected.

Mains	Loop	RLY1	RLY2 PRESENCE
ON	not occupied	0	0
ON	occupied	1	1
OFF	not occupied	0	0
	not occupied	1	0
	not occupied	0	0

- The error supervision mode can be set for FAIL-SAVE or FAIL-SECURE.

Cleaning

- Carefully wipe down the casing with a damp, lint-free cloth.
- Do not use any cleaning agents containing solvents. These pose a health risk and can damage the casing surface.

Disposal

Waste electrical products and batteries may not be disposed of with household waste!

Dispose of the waste product via a collection point for electronic scrap or via your specialist dealer.



Put the packaging material into a container for cardboard and paper.



SENS Setting the Sensitivity

The sensitivity can be set for various vehicle types:

The settings "MED-HIGH" or "MED-LOW" are optimized for the majority of applications. For vehicles with minimal metal mass (e.g. bicycles), the sensitivity can be set at HIGH.

Switches 3, 4: sensitivity channel 1

- HIGH - Hoch
- MED HIGH - Mittelhoch
- MED LOW - Mittel
- LOW - Niedrig

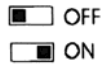

Change in inductance $\Delta L/L$ in the case of various vehicle types (loop 2m x 1m, 3 windings):

- Bicycle 0.02%
- Motorcycle 0.12%
- Truck 0.4%
- Car >1.0%

ASB Automatic Sensitivity Boost

If the ASB is switched on, when a vehicle is detected the sensitivity of the detector is automatically increased to the maximum. In this way long truck combinations and vehicles with high-set chassis can be reliably identified and premature closing, e.g. of a barrier, prevented.

Switch 5: ASB



Example: signal sequence for long truck combinations with and without ASB:

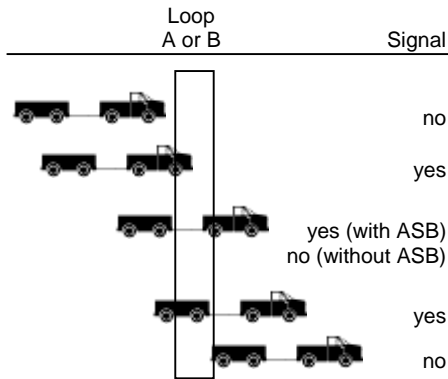

PRES Signal Holding Time

The signal holding time can be set via switch 8 for either PERMANENT PRESENCE or LIMITED PRESENCE.

Switch 6: PRES



At the "PERMANENT PRESENCE" setting, the detector will constantly compensate for all atmospheric and environmental influences as long as a vehicle occupies the loop.

At the "LIMITED PRESENCE" setting, the detector will constantly compensate for all atmospheric and environmental influences for the duration of approx. 45 minutes, after which the output is automatically reset.

Supply package, Accessories

ILD Induction Loop Detector, Operating Instructions

Accessories: Connecting base "ILD-RELEASE"

Safety Advice

- Before connecting and putting the unit into operation, carefully read through the Operating Instructions.
- Electrical installation and programming may only be carried out by a qualified electrician!
- Have faulty units checked by the manufacturer!
- Do not make any unauthorized alterations or modifications to the unit!

Designated Use

- The unit may only be used as a decoder device for induction loops!

Unpacking

Unpack the items supplied. Check that the delivery is complete!

- Dispose of the packaging in the designated collection containers for the recycling of cardboard, paper and plastic.

Description of Function

Together with the wire loops laid in the ground, the induction loop detectors are designed for detecting vehicles (metal masses) and triggering an action.

They can be used for controlling parking lot barriers, warehouse rolling shutters, garage doors or also for detecting vehicles in front of, for e.g. automatic traffic lights.

Special Features:

- Automatic self-adjustment on the loop connected as well as after altering the unit's settings. This guarantees that the unit is easy to put into service and to operate.
- Maintenance-free thanks to automatic compensation of atmospheric and environmental influences.
- Adjustable sensitivity and automatic sensitivity boost to reliably identify various vehicle types.
- Output via floating relay contacts with a max. contact rating of 5 A / 230 V AC.
- Indication of operating state and malfunctions via LEDs.
- The error supervision mode can be set for FAIL-SAVE or FAIL-SECURE.

Functional Restrictions

"Cross-talk"

If the loops of two detectors are located directly next to each other, then the magnetic fields can overlap and cause interference, resulting in malfunctions. This can be avoided by taking the following measures:

- Set different working frequencies on the detectors. The closer the loops are to each other, the greater the difference in frequency should be.
- Increase the distance between the two loops (> 2 meters recommended).
- If the feeder cable is laid next to other electric cables, it should be shielded. This shielding only needs to be earthed on the detector side.

"Reinforcements"

Steel reinforcements under the road can adversely affect the performance of the loop detection system. This interference can be reduced by taking the following measures:

- Add two more windings to the loop.
- Select the maximum distance possible between the steel reinforcement and the loop cable.

Installation Instructions

"Detector"

- Attach the detector in a suitable weather-protected location.

"Feeder cable and loop cable"

- The feeder cable and loop cable should be of the same material. Junction points between the loop and feeder cable should be avoided.

The cable must be of the insulated wire type with a cross-section of >1.5 mm² (recommended: loop cable type SIAF 1.5 mm²).

- The feeder cable must be twisted with approx. 20 turns per meter.
- The sensitivity of the loop reduces, the longer the feeder cable is. The feeder cable should therefore be as short as possible and not exceed 100 meters in length.

Installing the Induction Loop

- The length of the loop is determined by the width of the road to be monitored. It should extend up to 300 mm from each edge of the road (fig. 4).

Fig. 4

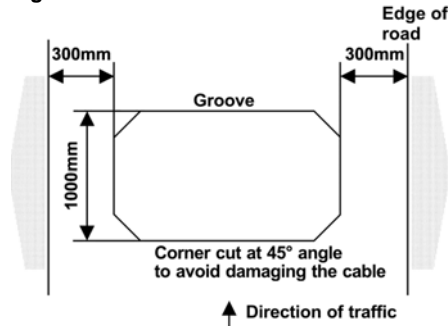

- Given the size of loop stated below, the following number of windings are required:

Size of loop	Number of windings
3 - 6 m	4
6 - 10 m	3
10 - 30 m	2

- Place the loops in the grooves which must be cut into the road surface (fig. 5). To accommodate the feeder cable, a groove should be run from one corner of the loop to the corner of the road.

Nominal groove width: 4 mm
 Nominal groove depth: 30 – 50 mm

Settings and Adjustments

Important:

Each time the settings on the unit have been altered, the RESET button must be pressed!

The unit then automatically performs a self-adjustment!

Make sure that the induction loops are not occupied while self-adjustment is taking place since also the sensitivity of the loop is redetermined during this process.

FREQ Setting the Frequency

If, for example, two detectors are installed, the risk of cross-talk between adjacent induction loops can be avoided by setting different working frequencies on the detectors (see also "cross-talk" in the section "Functional Restrictions").

Switches 1, 2: setting the frequency

HIGH	approx. 140 kHz
MED HIGH	approx. 100 kHz
MED LOW	approx. 60 kHz
LOW	approx. 20 kHz



- The loop corners should be set at an angle of 45° in order to avoid damaging the cable (fig. 4).
- Twist the feeder cable to the detector (> 20 turns per meter).

Fig. 5

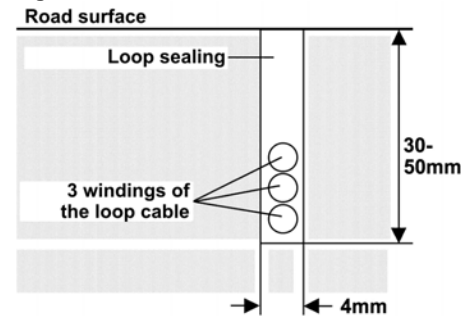

Putting into Operation

Connect the induction loops, the relay outputs and the supply voltage. Please note:

ILD11 connections 1, 2 230 V AC
ILD12 connections 1, 2 12 - 24 V AC/DC

After being switched on for the first time, as well as following a power failure or after every RESET, the detector automatically performs a self-adjustment (depending on the set frequency "FREQ", the LED CH1 flash 4 to 7 times).

After the automatic self-adjustment has been completed, the ON LED lights up. The unit is now ready for operation.

Operating Mode Indicator

- ON** The ON LED indicates that the detector is ready for operation
- CH1** Glowing constantly: loop A occupied
Flashing: loop malfunction